

# SLIM, TWIN TWIST, FLOOR MODEL SOFT SERVE/YOGURT FREEZER WITH REFRIGERATED CAB

F431



- Maintains high production capacity in high temperature conditions. Provides greater reliability and quieter operation with the combination of Stoelting's high efficiency evaporator system and Scroll™ compressor.
- Refrigerated mix storage cabinet holds two 5-1/2 gallon mix containers, a slide-out mix shelf, and two mix pumps.
- IntelliTec™ control with LCD display communicates with operator for worry-free operation (NAFEM Data Protocol capable).
- Mix pumps inject the exact amount of air into your mix, maintaining consistent overrun to assure maximum profitability with clean-in-place simplicity.
- Long-wearing parts offer low preventative maintenance costs.
- Energy Conservation Mode (ECM) protects product from over-agitation during slow or non-draw periods.
- Proprietary auger design gently folds mix and prevents product breakdown, producing a smoother, creamier product.
- Clear door shows visible moving product for merchandising appeal.
- Self-closing spigot eliminates waste and assures precise portion control.
- Adjustable dispense rate for optimal product output.
- Built for consistent control of all mixes, including low-fat, low-sugar mixes.
- Ideal choice for locations where space is an issue.
- Optional bag connection system eliminates potential contamination sources.



*Refrigerated Storage Cabinet  
showing slide-out tray and  
bag connection system.*



**AIR AND WATER-COOLED MODELS**

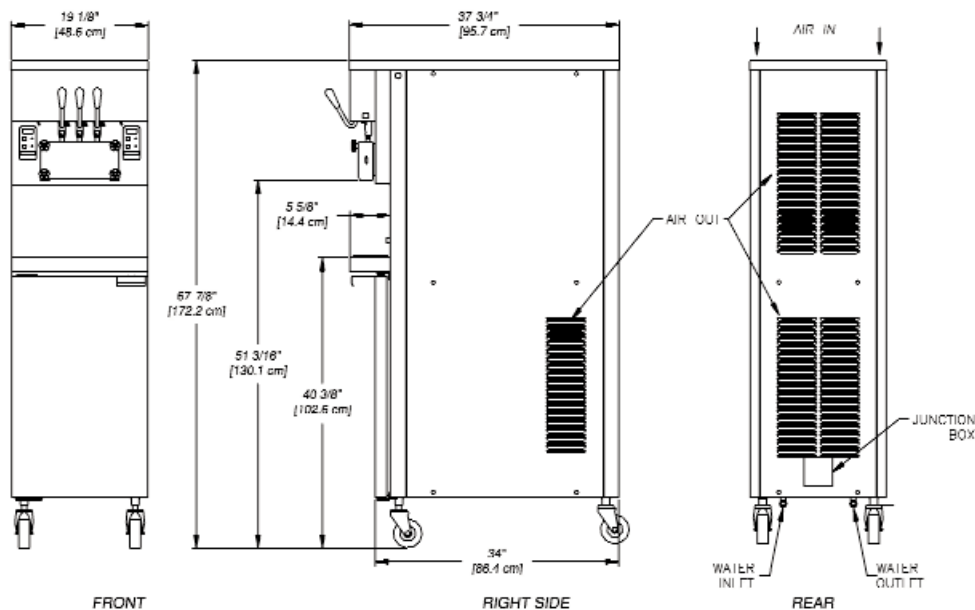

		<b>Model F431</b>	
<b>Dimensions</b>	<b>Machine</b>	<b>with crate</b>	
width	19-1/8" (48,6 cm)	27" (68,6 cm)	
height	67-7/8" (172,4 cm)	78" (198,1 cm)	
depth	37-3/4" (95,9 cm)	48" (121,9 cm)	
<b>Weight</b>	500 lbs (226,7 kg)	650 lbs (294,8 kg)	
<b>Electrical</b>	<b>1 Phase, 208-230 VAC, 60Hz</b>		
circuit ampacity	24A minimum		
overcurrent protection device	30A maximum		
International Option	1 Phase, 220-240 VAC, 50Hz		
<b>Compressor</b>	11,000 Btu/hr Scroll™ Compressor		
<b>Drive Motor</b>	Two - 3/4 hp		
<b>Air Flow</b>	Air cooled units require 3" (7,6 cm) air space on both sides, 6" back.		
<b>Plumbing Fittings</b>	Water cooled units require 1/2" N.P.T. water and drain fittings.		
<b>Hopper Volume</b>	Two - 5.5 gallons (20,82 liters)		
<b>Freezing Cylinder Volume</b>	Two - 0.85 gallon (3.4 quart), 3,22 liters		

*Continuous research leads to ongoing product improvements; therefore, these specifications are subject to change without notice.*

Distributed by:



**FOODSERVICE EQUIPMENT**  
 502 Highway 67 • Kiel, WI 53042-1600  
 920-894-2293 • 800-558-5807  
 Fax: 920-894-7029  
 E-mail: [foodservice@stoelting.com](mailto:foodservice@stoelting.com)  
[www.stoeltingfoodservice.com](http://www.stoeltingfoodservice.com)

ISO 9001:2000 Registered

Certified, Listed and/or Recognized by:

